

Hydrolift/Destoner

The Vanmark Hydrolift/Destoner can be suited to many product applications. It serves two key functions. First, it rinses product and separates non-floatable debris from the process stream. Second, it elevates product using a minimum of floor space.

As product is released into the receiving tank, a constant speed vertical auger creates turbulence in the water. This motion helps separate rocks from the product, washes any loose dirt from it and moves the product to the lift position.

The auger then lifts the product to the discharge point for transfer on to the next step in your process. The separated debris settles to the bottom of the tank. It can be removed manually or by an optional Series 2200 or 2300 Rock Remover

Discharge heights from 72" to 336" (approx. 1.8 to 8.5m) and capacities up to 50,000 pounds (22,700kg) of product per hour are available.

For more information about the Series 2000 or 2100 Hydrolift/Destoner visit our website at www.vanmarkequipment.com or contact our sales department for assistance in selecting a configuration suitable for your application.



Model 2000 shown set to receive a Series 2200 Automatic Rock Remover.

Series 2000

Features

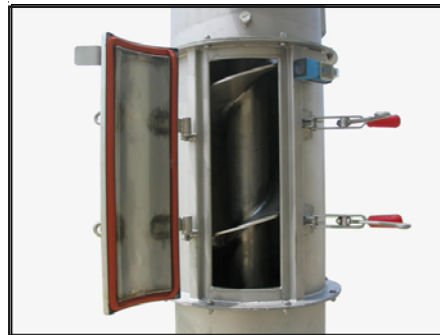

Optional auger access door makes clean-up and sanitation easier and faster.



The optional Rock Remover (shown attached) removes rocks and other non-floatable debris automatically.



VANMARK®

A business of the GROTE COMPANY

Dimensional Drawings

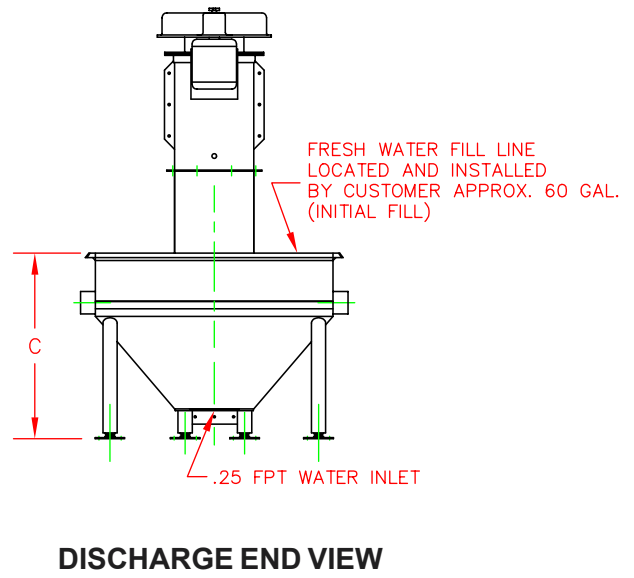
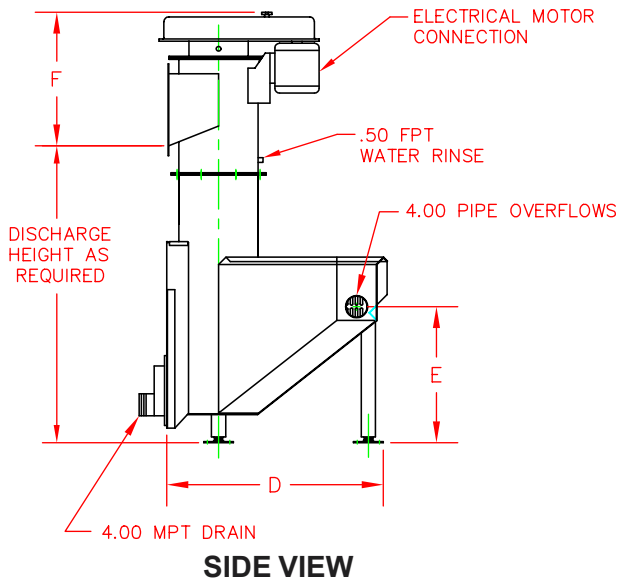
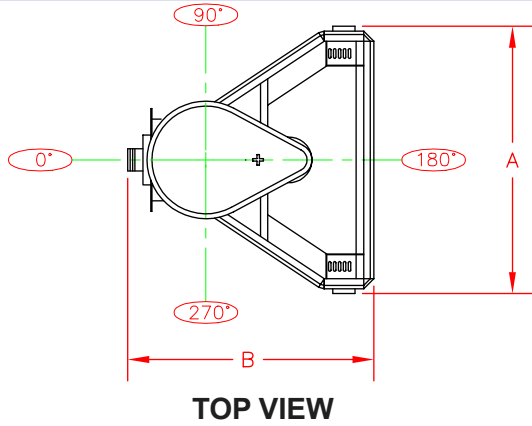

Options

- Tank Clean-Out Door
- Auger Clean-Out Door
- Series 2200 or 2300 Rock Remover
- Discharge Height and Direction to Suit Installation Requirements
- Series 2000 processes up to 25,000 lbs (11,350 kg) per hour.
- Series 2100 processes up to 50,000 lbs (22,700 kg) per hour.

Specifications

Model 2000 Model 2100

- Motor 230/460 v, 3 ph, 60 Hz ... 2 hp 10 hp
- Weight (approx) 1,500 lbs 2,200 lbs
- Dimensions

A	54.0"	66.4"
B	49.7"	60.3"
C	37.5"	39.3"
D	43.7"	55.0"
E	27.5"	33.9"
F	27.0"	39.3"



VANMARK®

300 Industrial Parkway
Creston, Iowa 50801

Tel.: Toll Free in the U.S.A. 800-523-6261 or
641-782-6575

www.vanmarkequipment.com
sales@vanmarkequipment.com

Turning product into profit...
for over 50 years

Peelers, Scrubbers, Washers and more

A business of the GROTE COMPANY